

Wiring your Winch with the New Block Solenoid

The new solenoid blocks are easier to wire and safer to use.

Things you need to be aware off before you start.

- The new solenoid blocks have different connections when compared with the older 'can style' solenoids.
- Cable Colours vary between makes and models of winches.
- You need to identify each of the winch terminals correctly (A, F1, F2, Ground), before you start. Getting this wrong can melt things.
- The position of the winch terminals varies between winches.
- The solenoid terminals are often not labelled. Use the relative position as a guide, or confirm with a multi-meter.

Copyright Eon4wd www.eon4wd.com.au

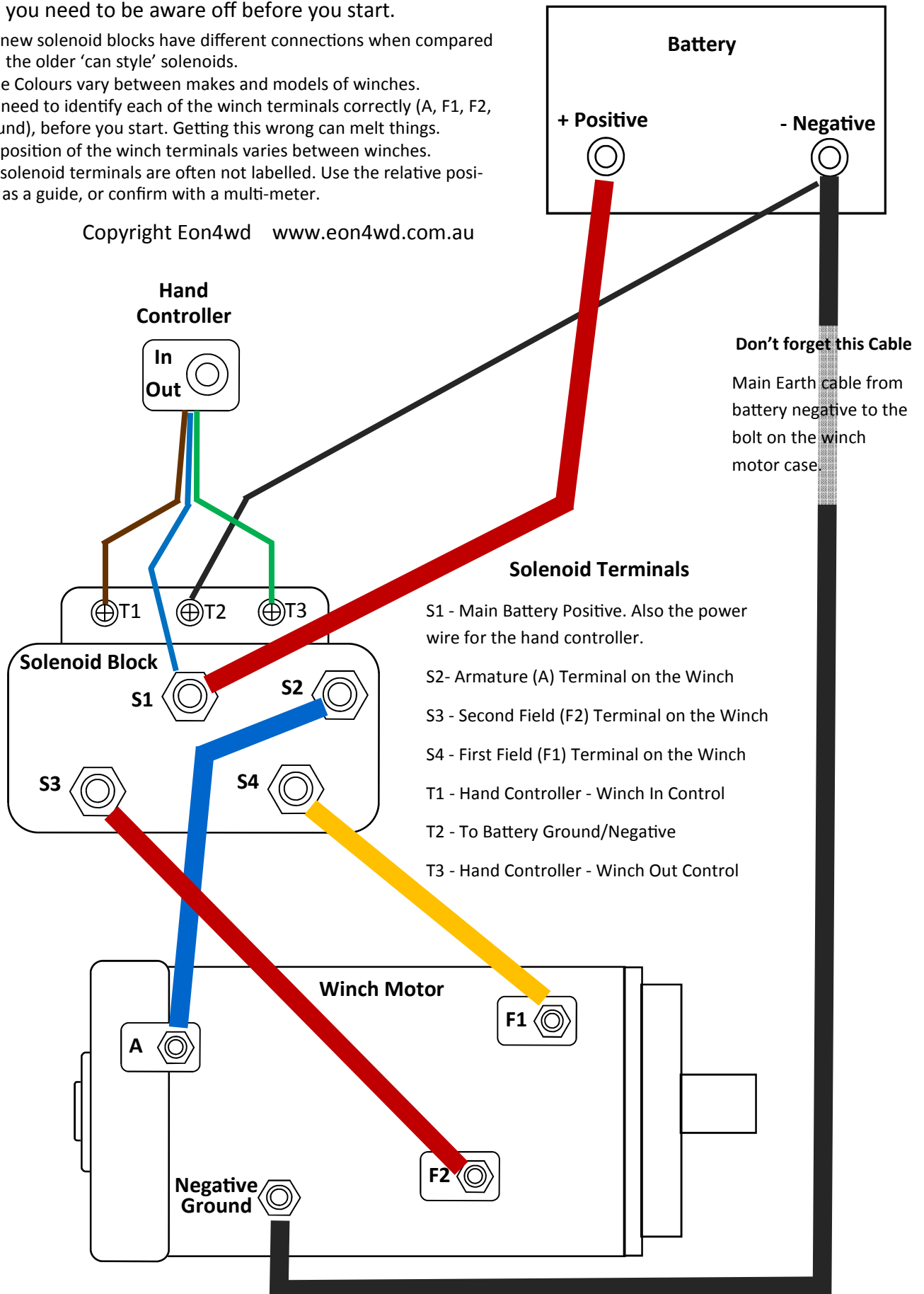

Winch Wiring Schematic

Using the newer Solenoid Block

Copyright Eon4wd www.eon4wd.com.au

If you have any questions, info@eon4wd.com.au

